

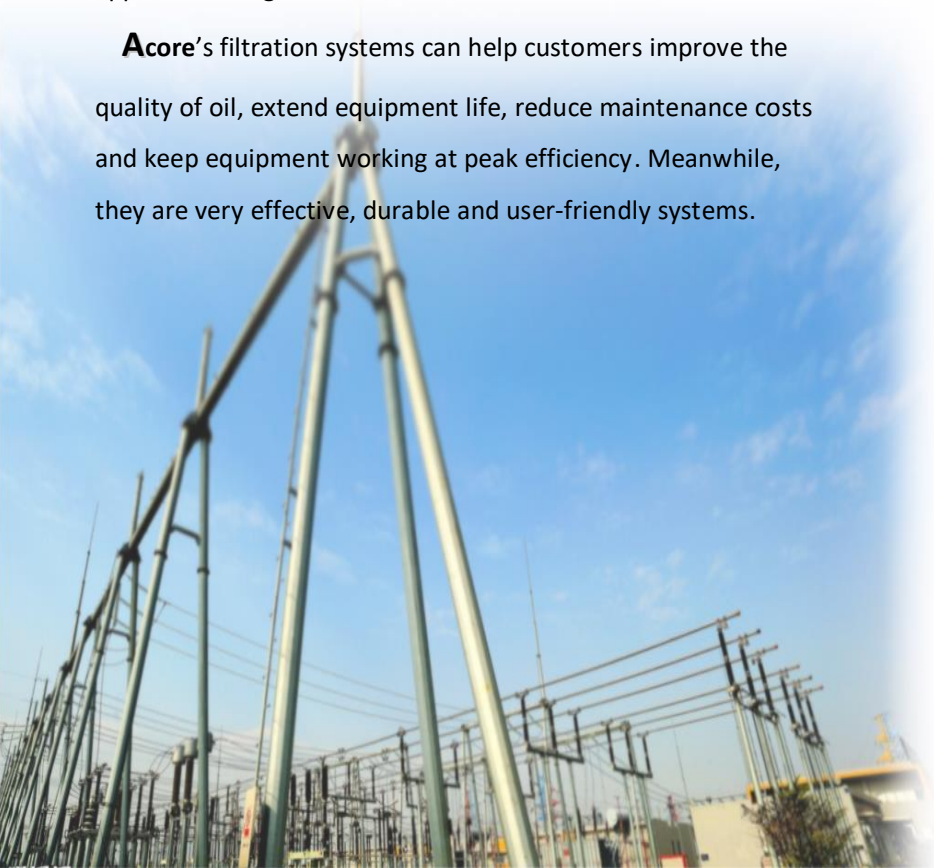

VTP SINGLE STAGE VACUUM TRANSFORMER OIL PURIFIER

Acore Filtration Co.,Ltd provides engineering, manufacturing, sales of industrial oil filtration systems, we have been striving for studying the user's requirement and provide filtration solutions for every demanding application on global scale.

Acore's filtration systems can help customers improve the quality of oil, extend equipment life, reduce maintenance costs and keep equipment working at peak efficiency. Meanwhile, they are very effective, durable and user-friendly systems.



Introduce:

The principal functions of the insulating fluid are to serve as a dielectric material and an effective coolant. During running of oil-filled electric equipment or transportation, the insulating oil becomes contaminated with moisture, gases and solid particulates, which results in complete deterioration of insulating properties and affect the life of the electric equipment in the long run. So it becomes necessary to maintain optimal insulation properties of oil by controlling over moisture, dissolved gases, particulate contamination.

AOCRE designed and manufactured VTP Single Stage Vacuum Transformer Oil Purifier Machine is designed for filtration, drying and degassing treatment of transformer insulating oils, this vacuum purification processing is a widely accepted and more economical method of treatment of insulation oil to increase and maintain insulating properties. Even new insulating oil is not enough clean to be used in high-voltage electric equipment, as it is often polluted during transportation tank and may absorb too much moisture and dust in contact with air, so new oil also needs purification processing before filling into transformers. The purification range of VTP Vacuum Transformer Oil Purifier is for dielectric insulating oil filled in transformers, circuit breakers, capacitor, cable, mutual inductor and other insulating oils.

Feature:

- Increasing oil's dielectric strength by effectively removing solid particles, gases and moisture, thus eliminating the need for expensive oil replacement, and thereby extending the life of the electrical equipment.
- System is operated & monitored via use of control panel
- Special designed system in the degassing tank which provides uniform distribution of the processed oil in the low-pressure environment to achieve best treatment results.
- Different pressure gauge of filters, pressure protector, vacuum gauge and digital temperature gauge
- Digital type electric heating system and safety thermostat, which is designed to allow temperature range of 20-80 °C
- After purification: Dielectric strength: 50 kV or higher,
Moisture content: 5 ppm or less
Gas content: 0.01% by volume or less,
Filtering rating: 1 micron or less.



Technical Specifications

Model	VTP-10	VTP-20	VTP-30	VTP-50	VTP-80	VTP-100	
Capacity(L/min)	10	20	30	50	80	100	
Vacuum level	-0.06 ~ -0.095 Mpa						
Working pressure	≤ 0.4 Mpa						
Temperature range	20 ~ 80°C						
Continuous work	≥200 hr						
No failure running	≥5000 hr						
Power supply	380V, 50HZ, 3PH (or Customized)						
Working noise	65 dB						
Heating power (kw)	15	15	24	30	45	60	
Total power (kw)	16.5	16.5	26	32	50	66	
Inlet/outlet(mm)	25	32	32	38	44	50	
Weight (kg)	300	320	350	400	500	600	
Dimension (mm)	L	1000	1100	1200	1300	1350	1400
	W	750	800	850	900	1000	1000
	H	1100	1200	1300	1300	1350	1750

Specifications After Treatment

Item	Specifications
Breakdown voltage	≥ 50 KV
Water content	≤ 4 ppm
Gas content	≤ 0.1%
Filtering rate	≤ 1 micron (ISO 14/12/10)
Flash point (close cup)	≥130°C
Interfacial tension performance	> 40 Dynes / cm @ 25 C
Power factor performance	< 0.01 % @ 25 C

Flow Chart

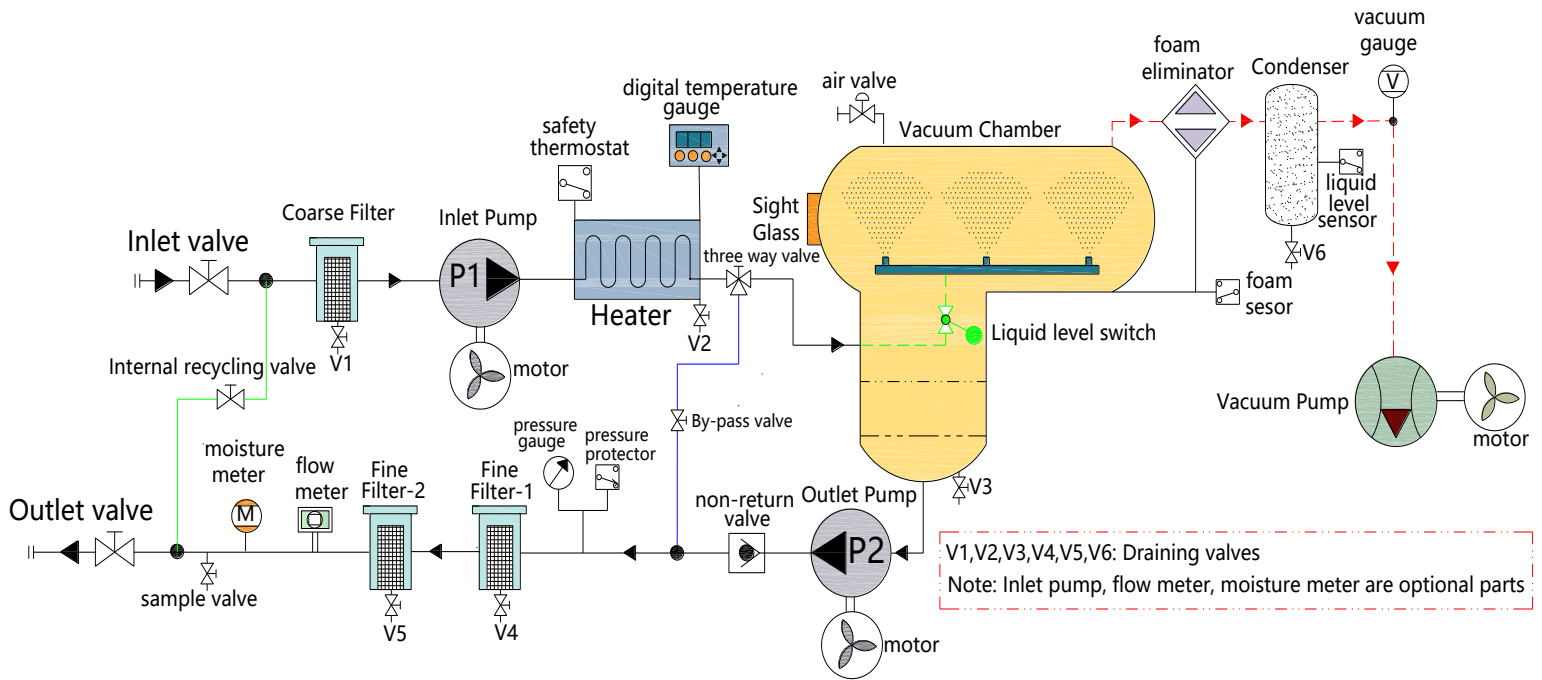

Components Specification of Systems

Electric Control System

All electrical control gear, mains Isolating arrangement, starters, contactors, Indicator lamp, push buttons, fuses, relays, Interlocking protecting device etc. are housed in a compact control panel sheets. A mimic diagram is provided.

The main components of the electrical apparatus can ensure the safety of the controlling system. The interlocked protective system and pressure protective device which will avoid overload, over voltage, pumping without oil, heating without oil, oil leak, electricity leak and prevent any damages to equipment due to operating error or power failure.

Vacuum Dehydration & Degasification Chamber

Vacuum dehydration & degasification chambers is composed of one evaporation chamber. The prayer is provided in vacuum chamber, which leads to the formation of film-alike oil and stereo-evaporation and ensure efficiency removal of gas and moisture.

Heating system

The unit equips a digital temperature controller as a safety thermostat, which has a reliable thermocouple sensor mounted in a pocket inside the vessel. The temperature can be set by manually and with capable of heating oil from 20°C to 80°C. the designed temperature range can protect the safety both device and worker. The deterioration of the oil caused by overheating is avoided.

The heating components can warm up temperature around and heat radiation container can uniformly warm up the oil, adopting low load of heated surface, less than 1.5W/cm².

Inlet & Outlet Pump

Inlet pump(Optional): Positive displacement gear type driven by electric motor; flow control valve & pressure safety valve against over-pressure is provided. Interlocking arrangement is provided between the inlet pump and the heater I, so that the heater cannot be energized unless inlet pump is ON.

Outlet Pump: suitable for sucking oil from the vacuum chambers held under vacuum. This is fully tested for pressure and vacuum leak rate. The pump is of robust construction and capable of developing pressures of up to 200 PSI. Interlocking arrangement is provided between low level float switch and discharge pump to prevent dry running of discharge pump.

Vacuum Pump

A rotary vane vacuum pump is a sort of vacuum production equipment suitable for pumping air and make the oil purifier working under high vacuum status. A condenser between vacuum pump and vacuum chamber reduces the temperature of vapor and avoids the vacuum pump damaged by high temperature of vapor.

Filtration System

Coarse filter: the coarse filter uses to prevent any damage to the inlet pump. It has strong capacity of retaining all particles above 100 micron. It is possible to clean the strainer without dismantling the filter.

Fine filter-1: This filter element is made of specialized glass fiber, which has large impurities holding capacity and can retaining all particles above 10 micron.

Fine filter-2: This filter element allows to accept a standard filter separating particles as small as 1 micron.

Pressure gauge and pressure protector is provided to ascertain condition of the filter vessel and indicate replacement of filter elements to avoid the overpressure to break the filter elements.

Liquid-level controller

The automatic liquid level control switch is provided in the vacuum chambers to protects the vacuum chamber from over-filling and too low oil. It connects with inlet/outlet pump, electromagnetic valve to control balance of inlet and outlet oil quantity, it prevents oil penetrating into the vacuum pump, prevent the oil level in the chamber to get too high and too low, avoiding to outlet pump running without oil.

Condenser

An air cooling condenser condenses the vapors to water where it is collected in a condensate tank. The condensate tank includes a high level switch that shuts the system down and lights a light on the control panel; automatic water drain is also available.

Pipe Work:

All pipe work, the vacuum chamber and the filter housings are made from high quality carbon steel. The piping joints are flanged type with O'ring sealing.

Valves

Different ball valves: inlet/out valves, drain valves, air valves, electromagnetic valves, sample valve, etc. are provided.

Oil Hoses

Two Nos. transparent steel spring type hoses each 10 meters long with flanged end connection on both sides are provided. Oil Hoses capable of handling the transformer oil at 100°C (max.) and vacuum.

Optional Equipment Available



Weather-proof



Double axles trailer



Single axle trailer